

New STL/TSL Solutions for LAN/WAN Extension to Transmitter Sites

***Presented at the 2005 National Association of
Broadcasters Annual Convention
Broadcast Engineering Conference Session
"IT in the Radio Broadcast Facility"
April 18, 2005***

Bill Gould, Broadcast Sales Engineer
Moseley Associates, Inc.
Santa Barbara, CA, USA



Contact:
bgould@moseleysb.com
(978) 373-6303

New STL/TSL Solutions for LAN/WAN Extension to Transmitter Sites

BILL GOULD

Moseley Associates, Inc.
Santa Barbara, CA, USA

ABSTRACT

Studio to Transmitter Link (STL) has historically meant a one-way audio path from the studio to the transmitter site. New broadcast applications such as remote mirrored servers, RDS and IP addressable equipment place bidirectional data requirements on the once simple STL. HD Radio™ deployment now requires an Ethernet connection to the IBOC transmitter. This paper discusses the expanding data requirements and new solutions for digital STL/TSL data transport and adding LAN/WAN connectivity to the transmitter site.

INTRODUCTION

The distinction between Information Technology (IT) and Broadcast Technology has become obscured in recent years. IT solutions can be harnessed to protect valuable broadcast assets, increase the reliability and overall efficiency of station operation and improve the effectiveness of station personnel.

This paper will discuss various applications for data connectivity and STL solutions for them. It is intended for IT professionals, broadcast engineering managers and engineering generalists. It is meant to inspire creative solutions to the unique challenges found in individual broadcast facilities.

DATA APPLICATIONS AT THE TRANSMITTER

RBDS

Radio Broadcast Data System (RBDS) is being rapidly deployed with large group operators making company-wide commitments to the technology. Digital STL systems do not allow injecting the RBDS subcarrier into the composite signal at the studio site, a common practice in the analog STL world. The RBDS song title and artist data needs to be delivered to the transmitter site. Depending on the policy of the individual station or group this is done as either an RS-232 serial data stream or over an Ethernet connection.

Off-Premises Mirrored Servers

The tragic events of 9-11-01 brought new attention to the vulnerability of broadcast facilities. While events of that magnitude are unlikely, accidents happen and

building evacuations due to a water main break, gas leak or electrical emergency are foreseeable events. A tremendous portion of a station's assets lies in the business records and programming content stored as data on the local area network (LAN). Off-premises mirrored servers provide security from the loss of valuable content and business records in the case of a catastrophic event at the studio building. These servers can be set to continually update over a relatively slow speed connection. The data stored in the remote server can then update the servers at the studio when they are restored to service. A logical place to locate a mirrored server is at the transmitter site. This provides an added level of redundancy in the ability to go on-air from the transmitter site in the event of a studio building closure.

Transmitter Remote Control

Transmitter remote control and telemetry links have been changed by the transition to all digital air chains. Digital STLs do not allow for remote control commands over an imbedded subcarrier like their analog predecessors did. Instead, RS-232 serial data channels provide quicker commands. Telemetry updates over a digital return channel are far more reliable than an over the air subcarriers or dial-up connections.

Major manufacturers of transmitter remote control systems have introduced browser-based interfaces using Internet Protocol (IP) connectivity. These systems provide distributed control so personnel can monitor transmitter site performance and take corrective action from any computer located on the local area network or from home on an Internet connection. Station engineers can avoid the frustrations of that late night telephone call guiding a part-time operator through a critical transmitter change. Eliminating the need for an engineer to drive in from home saves time, money and major inconvenience. Thus distributed control improves the engineers' response and reduces off-air time.

IP Addressable Products

IP addressable products further the convenience of distributed control. In certain digital STL topologies and with the present deployment of HD Radio™, audio processing is located at the transmitter site. In these

stations, making critical audio processing adjustments from the studio location is far preferred to a background of noisy transmitter cooling blowers. Often these sites are located miles from the studio location. Distributed control eliminates miles of driving just to make a subtle tweak in the station's sound. Soon all major components in the broadcast chain will sport Ethernet connections and browser-based control interfaces.

Surveillance and Security

Visual surveillance at a transmitter site once meant expensive industrial style cameras, dedicated monitors and expensive radio links. Today a simple low-cost webcam allows station personnel to observe the transmitter site from any computer located on the station LAN or connected to the Internet.

Internet and Email

Once a network connection is established at the transmitter site, station engineers are quick to find and locate a spare computer there. The ability to send and receive email or access a manufacturer's website to view or download a manual can save valuable lost time driving back to the studio. If this occurs during a midnight maintenance session or off-air emergency the monetary value of the time saved is dramatically increased.

DATA REQUIREMENTS OF HD RADIO™

HD Radio™ for IBOC (In-Band On-Channel Digital Audio Broadcasting) includes an Ethernet data channel to the transmitter. The Ethernet stream is used to transport Program Service Data (PSD), Advanced Application Services (AAS) and Supplementary Program Service (SPS) data. PSD contains song title and artists as well as other information related to the program. Examples of AAS services that have been demonstrated are traffic reports with mapping, commercial and non-commercial expanded messaging services, timely weather and public safety bulletins. The SPS audio channels will provide stations with capabilities to broadcast additional separate program content at the same time as the Main Program Service (MPS) as is planned for Tomorrow Radio.

In the Exporter HD Radio™ scenario, the MPS digital audio, too, will be carried in the Ethernet stream. At present there are two distinct methods to deploy HD Radio™ for IBOC.

Current Generation HD Radio™

The current generation HD Radio™ requires a 44.1 ks/s AES digital audio channel and a 400 bps Ethernet stream. In this scenario the audio processing is located at the transmitter site along with the IBOC exciter. The

44.1 ks/s digital which provides 20 kHz audio response is transported to the transmitter site by the STL and delivered to the IBOC exciter. The IBOC exciter splits the audio into two streams. The audio signal destined for the legacy analog transmitter is time aligned with the digital, sent to the analog audio chain processor and to the legacy analog transmitter. The signal destined for the IBOC exciter is sent to the digital audio chain processing then returned to the IBOC exciter where it is encoded into the MPS digital signal for over the air broadcast.

PSD is delivered separately to the IBOC exciter on a 400 bps Ethernet data stream. SPS audio is also delivered separately on additional STL channels. Data for AAS when used would require a separate delivery path as well.

Transporting all the components of the IBOC broadcast to the transmitter site individually challenges STL bandwidth than is currently available in either a 950 MHz STL channel or on a T1 circuit used for STL. A more bandwidth efficient approach to IBOC transport will allow currently available STL systems to be utilized.

HD Radio™ Exporter Platform

The Exporter Platform often called Exgine, is a decidedly more bandwidth efficient method of deploying HD Radio™. Transport requirements are 44.1 or 32 ks/s sampled AES digital audio and a less than 300 kbps Ethernet stream. This platform consists of two additional products one called the Exporter and one the Importer.

The Exporter and Importer along with the audio processing are located at the studio site, a practice that is generally preferred by station engineers. The Exporter performs two functions, handling the MPS digital audio and PSD. It also accepts the AAS and SPS coming from the Importer, combining all these services for transport over the STL to the transmitter site.

The main program digital audio is delivered to the Exporter which splits the audio into two streams. One is sent to the analog audio chain processing and one to the digital chain processing. Both streams are returned to the Exporter after processing. The audio destined for the legacy analog transmitter is time aligned with the digital and sent to the AES digital input of the STL for transport to the legacy analog transmitter. The audio destined for the IBOC exciter is encoded into the MPS signal for the digital over the air broadcast.

Meanwhile, the Importer accepts data inputs for the AAS services and audio inputs for SPS. These services are then sent to the Exporter by a <300 kbps bidirectional UDP Ethernet data stream.

The SPS and AAS data are combined with the MPS and PST in the Exporter into a single data stream which is transported by the STL as a <300 kbps UDP Ethernet data stream to the IBOC transmitter for broadcast.

Figure 1: HD Radio™ Exporter Platform

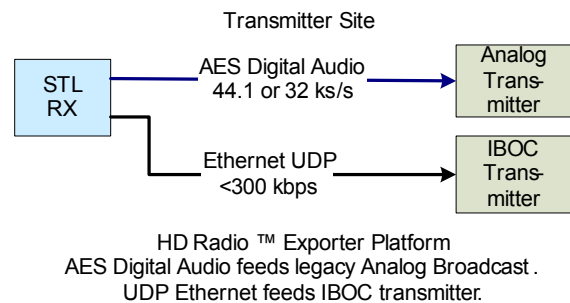
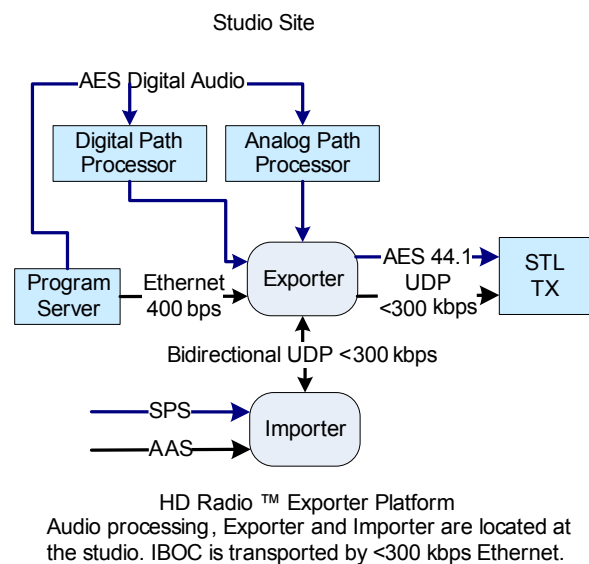

Since in the Exporter Platform, the AES digital audio only the legacy analog broadcast side of the transmission, which is band limited to 15 kHz audio response anyway, 32 or 44.1 ks/s sampling rates which provide 15 or 20 kHz bandwidth respectively are acceptable. Figure 1 details the audio flow in the Exporter Platform.

The 300 kbps number used to describe the Ethernet channel is more of a reservation for all future HD Radio™ modes than the actual bandwidth which will be consumed today. The current implementation and the Exporter platforms discussed in this paper are hybrid modes. These modes will operate at significantly less than 200 kbps of Ethernet throughput.

Regardless of method of implementation chosen for IBOC, the single common STL requirement is AES digital audio and an Ethernet data stream.

STL SOLUTIONS FOR DATA APPLICATIONS AND IBOC

In most cases the STL is the only full-time link between the studio and the transmitter site. Many of these transmitter sites are located in remote areas far removed from any high-speed network access. It is only natural that the STL be used to provide access to this site.

Possible STL solutions to data transport are:

- Add Ethernet capability to a 950 MHz STL
- Create a separate data link
- Data transport capabilities of a T1 STL/TSL

ADDING ETHERNET TO A 950 MHz STL SYSTEM

In areas where line-of-sight exists, the 950 MHz RF STL system is the de-facto standard for radio station program audio transport. The 950 MHz STL as its name implies is a one way microwave radio device which in the analog world was designed to convey a single stereo program to the transmitter site for over-the-air broadcast. Digital STL systems brought with them the ability to multiplex one or more additional services and transport them over a single link. In a digital STL system, adding additional outbound services such as serial RS-232 data channels, Ethernet connectivity and additional audio channels is possible up to the available bandwidth in the STL channel.

Figure 2: A 950 MHz STL with Ethernet

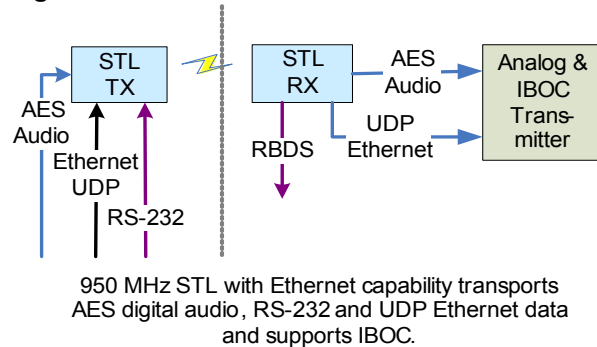

In some cases simple one way data circuits to the transmitter may be sufficient as shown in Figure 2. The Moseley Starlink SL9003Q STL system is an example of a system which can be equipped for data transport in addition to AES digital program audio. Starlink's audio Source Encoder and Decoder modules have a built-in RS-232 data channel. This serial data "rides for free" because it consumes no extra transport bandwidth. These RS-232 paths will support data for RBDS or the command side of a remote control system.

An optional multiplexer and Ethernet module can be added to the Moseley Starlink system as well. This can provide the one-way Ethernet UDP data path to the transmitter site necessary for IBOC.

The payload capabilities of a 950 MHz STL are a function of the allowable bandwidth of the channel it occupies and the QAM rate used (available on SL9003Q are 16, 32, 64, 128, 256 QAM). For example, at 32 QAM, a 950 MHz STL is capable of one 44.1 ks/s stereo audio channel and a ≥ 600 kbps Ethernet channel. This combination provides more than ample throughput to support IBOC in either configuration as shown in Table 1.

Table 1: Payload on a 950 MHz STL

Examples of Payload Combinations on a 950 MHz Digital STL @ 32 QAM		
Audio	Ethernet Data	Additional Audio Channels
One stereo pair uncompressed @ 44.1 ks/s and 1 RS-232	640 kbps unidirectional	X
One stereo pair uncompressed @ 44.1 ks/s and 1 RS-232	384 kbps unidirectional	One pair (2 ch.) compressed @ 256 kbps
Two stereo pair uncompressed @ 32 ks/s and 2 RS-232	X	X
Note: Other combinations of program audio, RS-232 and LAN data channels are possible up to the total channel bandwidth.		

Because this is a one-way path, true networking possibilities are greatly limited.

CREATING A LAN/WAN EXTENSION TO THE TRANSMITTER SITE

In addition to the outbound data connectivity available on a digital 950 MHz STL, an inbound return portion of the link is needed to provide true networking functions and bidirectional control and telemetry services. Up to now this has required licensing additional transmitter to studio link (TSL) channels or leasing circuits from the local telephone company.

When it comes to adding data services, broadcasters would prefer to avoid licensing delays and frequency coordination expense associated with acquiring new TSL frequencies or the recurring monthly expense that comes from leasing additional circuits from the telephone company.

Due to the extensive installed base of 950 MHz systems, an independent data transport link which works alongside a 950 MHz STL as shown in Figure 3 will solve broadcasters' data transport requirements in a large number of cases. These stations can continue to use already installed 950 MHz equipment infrastructure and leverage the STL channels they already have licensed. Moseley's Lanlink 900D LAN Extender provides this functionality.

Lanlink transports bidirectional Ethernet and RS-232 serial data over a license-free 900 MHz RF link. Because of the closeness in frequency to the 950 MHz STL band, Lanlink can be combined into an existing 950 MHz antenna system which eliminates the need to purchase and install an additional antenna system or add additional tower lease costs and tower wind loading. If desired however, a station can create a stand-alone data link by installing an antenna system for Lanlink.

Figure 3: 950 MHz STL with 900 MHz LAN Extender/Data Link

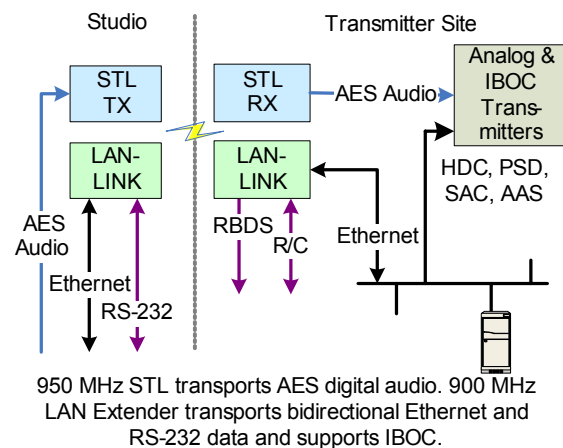

Lanlink operates in the 902-928 MHz ISM band so no license is required. It uses robust digital frequency hopping Spread Spectrum technology producing signals that can still be recoverable even with a very low signal-to-noise ratio. The power output is 0.1 to 1 Watt (20 to 30 dBm). This is sufficient to provide paths of up to 30 miles. As a general rule, where there is a working 950 MHz STL already in service Lanlink will operate comfortably. In these situations, it should not be necessary to conduct additional path studies.

Lanlink connects in-line between the STL transmitter or receiver and the 950 MHz antenna system. A built-in duplexer in Lanlink combines the RF output of the STL and that of the Lanlink with less than 1.2 dB of insertion loss. This eliminates the expense and additional tower loading of adding another antenna system.

The Ethernet data transport capabilities of Lanlink are 512 kbps 10BASE-T for IP/Ethernet connections. With Lanlink the station LAN can be extended to the transmitter site with enough bandwidth capabilities to support services such as remote servers and IP equipment control as well as the IBOC data stream including its MPS, SAC, PSD and AAS information. Two RS-232 channels provide bidirectional serial data paths that can be set to 1200-115,200 bps for remote control or RBDS.

Using Lanlink as the data path allows the STL system to be devoted to audio transport. The combination of Lanlink with Moseley's Starlink SL9003Q digital STL system can provide two or four and in some cases six audio channels plus the Ethernet connectivity to support IBOC and LAN/WAN networking applications plus RS-232 channels for remote control systems and RBDS.

Lanlink can be used with the Moseley Starlink SL9003Q digital STL system as well as all Moseley models and those of other manufacturers.

T1 STL/TSL SYSTEM FOR DATA TRANSPORT

T1 systems are well suited for program audio, voice and data networking. T1 is a 1.544 Mbps bidirectional data circuit. These circuits are commonly found as leased T1 circuits from the local telephone company, fiber links, T1 microwave or Digital Spread Spectrum radio links. T1 Spread Spectrum radio links occupy the unlicensed ISM bands located at 2.4 GHz or 5.8 GHz.

A T1 STL/TSL system should be considered if the answer is yes to any of the following questions:

- No line of sight path to the transmitter?
- 950 MHz frequencies overcrowded?
- Need to backhaul audio from RPU, satellite downlink, air monitor?
- Requirements include telephone voice channels for off-premises extension or remote PBX interconnect?
- Desire to save money by consolidating multiple leased voice or data lines onto one digital circuit?

STL using T1 circuits overcomes the problem of no line of sight to the transmitter building whether it is caused by local obstructions or longer distance requirements. Radio station clusters are often made up of individual stations whose transmitter sites are located far outside the city where the studios are located. T1 is a digital transport medium which delivers the same quality whether the circuit is across town or thousands of miles cross-country with no increase in noise or loss of audio performance.

The true benefits of a T1 system are found in its payload capabilities. In addition to digital program audio delivery to the transmitter, you have the full T1 bandwidth inbound (TSL) for program quality audio backhaul of satellite downlink channels, remote pickup (RPU) receivers co-located at transmitter sites, off air confidence monitoring or EAS receive audio.

Additional bidirectional audio services include 4-wire and 2-wire voice circuits for FSK transmitter control, FXO/FXS telephone, fax or intercom extension across the link. Data channels provide additional Ethernet and RS-232 data connections.

Figure 4: Block Diagram of a T1 STL/TSL

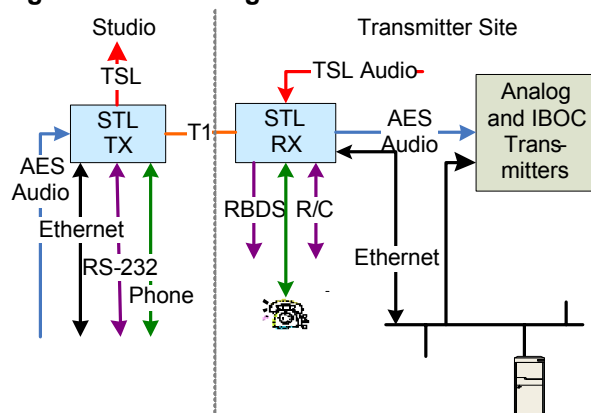

T1/E1 STL transports bidirectional AES digital audio telephone voice, Ethernet and RS-232 data and supports IBOC.

Payload Capabilities of a T1 System

Payload capabilities of a T1 system are limited by the 1.544 Mbps bandwidth of the T1 circuit. Of this available bandwidth, the bandwidth required to operate the audio channel at 44.1 ks/s is 1.408 Mbps. That allows approximately 80 kbps for the LAN connection. This is sufficient to carry the PSD component of HD Radio™ and to support some slow speed network capabilities. To take full advantage of the capabilities of the T1 circuit engineers choose to operate the audio modules at 32 ks/s sampling rates. This consumes 1.024 Mbps of the available T1 bandwidth leaving the remaining 512 kbps available for the LAN applications and other audio services.

Table 2: Payload on a T1 STL

Examples of Payload on a T1 Circuit		
Audio	Ethernet Data	Additional Audio Channels
One stereo pair uncompressed @ 44.1 ks/s and 1 RS-232	80 kbps	X
One stereo pair uncompressed @ 32 ks/s and 1 RS-232	512 kbps	X
One stereo pair uncompressed @ 32 ks/s and 1 RS-232	256 kbps	One pair (2 ch.) compressed @ 256 kbps
Note: Other combinations of program audio, voice, and data channels are possible up to the total bandwidth of the T1 circuit.		

The Moseley Starlink 9003T1 can be set up for either IBOC scenario. In fact, stations may elect to deploy the present platform with 44.1 ks/s AES digital audio and 80 kbps of LAN connectivity. In the future they may adopt the Exporter platform and simply reconfigure

Starlink for 32 ks/s AES audio and 512 kbps LAN data as shown in Table 2 for example. Starlink's open architecture allows for future upgrades and reconfiguration to react to changing transport requirements.

T1/E1 on 5.8 GHz

Digital Spread Spectrum radios offer a solution to stations preferring the benefits of an RF STL with all the payload capabilities of a T1 system. In a Spread Spectrum radio system the leased wired T1 line is replaced by a T1 2.4 GHz or 5.8 GHz bidirectional radio link. Spread Spectrum T1 radios are used by major telephone companies as the "last mile" to extend their networks into areas well beyond the reach of wired facilities.

Spread Spectrum radio use was originated by the military because of its robustness and security. The Spread Spectrum signal is "spread" over a much wider bandwidth than needed to transport the information using a unique spreading code. The receiver with the same code can recover the information in the presence of very low signal-to-noise ratios. This also reduces or eliminates the effects of interference which tends to be fixed frequency. For this reason, Spread Spectrum systems perform over greater distances or can use smaller antenna systems than fixed frequency radio systems in the same bands. Often paths of 30-40 Miles can be achieved.

This line-of-site STL solution operates license free in the 2.4 or 5.8 GHz ISM bands. T1 over Spread Spectrum radio avoids the recurring monthly costs of leasing T1 lines from the telephone company. Because the ISM bands are unlicensed, there are no expensive frequency coordination studies and license application fees. Systems can be deployed and changes made quickly.

Stations operating exclusively on microwave spread spectrum links can take advantage of an added bonus. Since they have no ties to the T1 network, these stations have the option of operating their systems at E1 rates. E1 is the international standard which operates at 2.048 Mbps instead of the domestic standard of 1.544 Mbps in a T1 circuit. This results in an additional 28% of payload capacity in E1 systems.

Table 3 shows some combinations of audio and data which are possible in an E1 system. Careful selection of the bandwidth assignments makes it possible to transport additional audio, voice and data services in an E1 system and support IBOC.

Table 3: Payload on an E1 STL

Examples of Payload on an E1 Circuit		
Audio	Ethernet Data	Additional Audio Channels
One stereo pair uncompressed @ 44.1 ks/s	512 kbps	X
One stereo pair uncompressed @ 32 ks/s	896 kbps	X
One stereo pair uncompressed @ 44.1 ks/s	256 kbps	One pair (2 ch.) compressed @ 256 kbps
Note: Other combinations of program audio, voice and data channels are possible up to the total bandwidth of the E1 circuit.		

Digital T1/E1 Spread Spectrum radio systems are available in 1, 2 or 4 T1 or E1 capacity. Using a 2 or 4 T1/E1 system is a perfect solution for a cluster of stations feeding combined transmitter sites. The combined payload of program audio, voice and data circuits to support multiple radio stations over a single high capacity link is a cost effective alternative to employing individual circuits for each station or service.

CONCLUSION

Implementing a data link to transmitter sites can provide stations with new functionality, efficiency and safety as well as lower operating costs.

Choosing the STL is as much a matter of preference as the payload. Choices range from a 950 MHz STL with data capabilities for one-way data applications to a 950 MHz STL and a 900 MHz LAN extender to provide bidirectional networking solutions. For more complex audio, voice and data networks T1 STL and T1/E1 STL over 5.8 GHz RF links can concentrate more traffic over a given link and be more payload efficient and save on transport link costs when compared to the multiple discrete services it replaces.

Web browser equipment control is fast becoming standard equipment on broadcast products. New low-cost IP based accessories are widely available at electronic discount stores. Station IT and engineering personnel can look forward to marrying these innovations with core broadcast technology to provide unique new solutions.

One thing is certain; the need for data access at the transmitter will surely grow. Choosing the STL system which is correct for the data application and has a migration path for future expansion is the best solution for LAN/WAN extension to the transmitter site.